



nexthardware.com

a cura di: Emanuele Chiochio - MAN - 21-03-2013 07:31

Canon annuncia le reflex APS-C 700D e 100D

Canon

LINK (<https://www.nexthardware.com/videographia/news/reflex/413/canon-annuncia-le-reflex-aps-c-700d-e-100d.htm>)

Rinnovata l'offerta entry con due nuovi modelli, uno promette di essere la DSLR più piccola al mondo

Partiamo, è il caso di dirlo, dalla più **piccola...** al mondo! Secondo **Canon**, la nuova **EOS 100D** è la reflex digitale più compatta e leggera attualmente in commercio: appena 407 grammi, batteria inclusa, e dimensioni lillipuziane, 117x91x69mm, più o meno a metà strada tra una **700D** ed una **EOS M**.

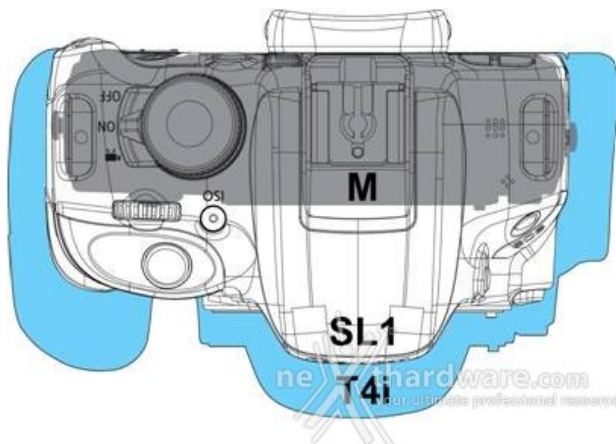

↔
Canon EOS 100D

Se all'esterno la reflex **Canon** s'è ristretta, dentro invece presenta una serie di *features* di tutto rispetto: sensore **APS-C CMOS da 18MPixel**, processore **DiGiC 5**, **AF Ibrido**, video **FullHD 30/25/24p** e

schermo posteriore touch, in posizione fissa, da 3".

Il prezzo rispecchia più la dotazione che le dimensioni, ragion per cui **Canon** chiede circa **650 Dollari USA** per il corpo macchina che salgono ad **800**, in kit con l'obiettivo **EF-S 18-55mm f/3.5-5.6 IS STM**.

La **700D** rinnova il *top end* della linea **Rebel**, di grande successo ed amplissima diffusione grazie alle numerose funzioni avanzate ed ad un *form-factor* ideale per molte occasioni e necessità .



Canon EOS 700D

Condivide praticamente tutto con la appena presentata **100D** ma aggiunge l'LCD posteriore articolabile, uno scatto a raffica di 5fps invece di 4 ed un corpo macchina caratterizzato da un'impugnatura più pronunciata.

Prezzi a partire da **750 Dollari USA** per il solo corpo macchina, che diventano **900** con l'**EF-S 18-55mm f/3.5-5.6 IS STM** e 1.100 con il nuovo↔ **EF-S 18-135mm f/3.5-5.6 IS STM**.

Congiuntamente alle due reflex, **Canon** introduce anche un nuovo obiettivo della linea **STM** ottimizzata per l'uso in ambito video in coppia col sistema AF ibrido che equipaggia le ultime digitali APS-C del Produttore: l'**EF-S 18-135mm f/3.5-5.6 IS STM** nasce per offrire una soluzione zoom compatta, dotata di sistema di stabilizzazione ottica (4 stop) e di tecnologia STM (Stepper Motor) per un AF ultra silenzioso.



Canon EF-S 18-135mm f/3.5-5.6 IS STM

Comunicati Stampa

Canon EOS 100D

CANON U.S.A. ANNOUNCES WORLD'S SMALLEST AND LIGHTEST DSLR CAMERA

MELVILLE, N.Y., March 21, 2013 MELVILLE, N.Y., March 21, 2013 - Continuing the quest to deliver superb product innovations, Canon U.S.A., Inc., a leader in digital imaging solutions, today announced the world's smallest and lightest DSLR* camera: the EOS Rebel SL1 Digital SLR Camera. It features a newly developed 18.0-megapixel CMOS (APS-C) sensor and high-performance DIGIC 5 Image Processor for exceptional image quality and speed. With its combination of lightweight size, ease of use and outstanding image quality, the EOS Rebel SL1 is perfect for users looking for the ideal camera to bring sightseeing on vacation or to capture the everyday.

'The EOS Rebel SL1 Digital SLR Camera represents a new era in DSLR versatility: ultra-portable, full-featured DSLR cameras,' said Yuichi Ishizuka, executive vice president and general manager, Imaging Technologies & Communications Group, Canon U.S.A. 'The EOS Rebel SL1 combines the high speed, high image quality and expanded shooting range of a DSLR camera, with the easy and fun usability of a point-and-shoot camera.'

As the world's smallest and lightest DSLR, the new camera body is 4.6" (w) x 3.57" (h) x 2.74" (d), and weighs only 14.36 oz.** In comparison, the EOS Rebel SL1 is approximately 25 percent smaller and 28 percent lighter than the EOS Rebel T4i digital camera.

The EOS Rebel SL1 features an 18 megapixel CMOS (APS-C) sensor that performs exceptionally well in both bright and dimly lit shooting environments with an ISO range of 100-12800 (expandable to H: 25600) for photos and ISO-6400 (expandable to H: 12800) for video. Canon's DIGIC 5 Image Processor technology allows for exceptional image quality and shooting speed up to four frames per second (fps).

The camera includes a new nine-point center cross-type autofocus (AF) system to help achieve fast, sharp focus. The new AF system also includes a new Hybrid CMOS AF II sensor, which provides a wider focus area when shooting photos or video in Live View mode, and a continuous AF speed that's increased from previous EOS models.

To help capture video with ease, the EOS Rebel SL1 features Canon's Movie Servo AF, which provides continuous AF tracking of moving subjects. When shooting video with one of Canon's new STM lenses, such as the EF-S 18-55mm f/3.5-5.6 IS STM (available in the standard lens kit), Movie Servo AF takes advantage of the lens' stepping motor for smooth and quiet continuous AF. The camera is capable of Full

HD shooting in a number of recording sizes and frame rates, and enables easy manual control of exposure, focus and Live View features. The combination of Canon's new Hybrid CMOS AF system II and EF-S 18-55mm f/3.5-5.6 IS STM lens is ideal for shooting video helping to ensure only the sounds of the scene are recorded.

Allowing for clear and easy viewing even in bright environments, the Touch Screen three inch Clear View LCD monitor II provides a rich and expansive display as well as providing intuitive touch panel operation. Two finger touch gestures (multi-touch) can be easily used for zooming or changing images, accessing menu and quick control settings, and activating focus point and shutter release while shooting

Creativity at your Fingertips

The EOS Rebel SL1 encourages users to explore their creative side with a wide array of features for convenience and simple shooting. The EOS Rebel SL1 is equipped with Scene Intelligent Auto Mode, an advanced function that detects faces, colors, brightness, movement, contrast, distance and other factors and automatically adjusts and selects the exposure method needed. The results are photos with a wide dynamic range, ideal for users without advanced photography knowledge or experience.

Users can also access advanced imaging features like the new Effect Shot mode, which automatically creates two different shots, one with a selected creative filter and one without. In addition, Creative Filters and Background Blur Simulation can now be displayed in real time during Live View shooting. Editing photos is also a snap with the Rebel SL1's in-camera editing and cropping functionality. This feature allows users to view and crop the image using the camera's LCD touch screen and save the edited version as a separate file.

For those who would like to take beautiful photos with ease, the EOS Rebel SL1 offers a variety of scene modes to explore. New special scene modes include Kids, Food and Candlelight, giving users advanced presets to help ensure the best possible photos even under difficult shooting conditions.

Pricing and Availability

The new EOS Rebel SL1 Digital SLR Camera is scheduled to be available in April for an estimated retail price of \$649.99 for the body alone or \$799.99 bundled with the new EF-S 18-55mm f/3.5-5.6 IS STM kit lens.

For more information about the EOS Rebel SL1 Digital SLR Camera, and a full list of product specifications, visit www.usa.canon.com/eos.

Canon EOS 700D

NEW CANON EOS REBEL T5i DIGITAL SLR CAMERA PACKS PERFORMANCE WITH NEW CREATIVE CONTROLS

MELVILLE, N.Y., March 21, 2013↔ - Canon U.S.A., Inc., a leader in digital imaging solutions, is proud to introduce a new flagship model to its popular EOS Rebel line, the EOS Rebel T5i Digital SLR Camera. The incredible image quality and performance starts with an 18 megapixel CMOS (APS-C) sensor and Canon's superb DIGIC 5 Image Processor. Combined with an extensive ISO range of 100-12800 (expandable to 25600 in H mode), the EOS Rebel T5i boasts crisp, detailed images, even in low-light conditions. With a continuous shooting speed of up to 5.0 frames per second (fps) united with 9 all cross-type AF focus points, the new EOS Rebel T5i allows photographers the opportunity to shoot with ease, even in challenging shooting situations.

When shooting in Live View mode, the Hybrid CMOS AF system enables speedy and accurate autofocus for photos and video. Coupled with Canon's new EF-S 18-55mm f/3.5-5.6 IS STM lens, available in the standard kit lens bundle, the EOS Rebel T5i takes full advantage of the Stepping Motor (STM) technology, which allows the lens to smoothly and silently focus on the subject whether it is moving or standing still. When combined with the camera's high-resolution Vari-angle Touch Screen 3.0-inch Clear View LCD monitor II and intuitive touch controls, the EOS Rebel T5i stands as Canon's most "consumer-friendly" DSLR.

'Built to make advanced photography creative and fun, the EOS Rebel T5i Digital SLR Camera gives users exceptional image quality and fast, intuitive operation along with creative functions to help advance photographic expression,' said Yuichi Ishizuka, executive vice president and general manager, Imaging Technologies & Communications Group, Canon U.S.A.

Expand Your Creativity with New Advanced Features

The EOS Rebel T5i provides amateur and advanced photographers looking to hone their creative and technical skills with a range of features that allow for crisp, clear images.

Whether it is adding saturation to a vivid landscape or applying a unique, vintage touch to a portrait, users who want to express their creativity can experiment with different effects and settings, composing a shot, by using one of Canon's seven Creative Filters. When the Creative Filters are applied in Live View, users can preview the filter on the vari-angle three inch LCD touch screen without having to shoot the image first. Effects such as ArtBold, Water Painting, Grainy Black and White, Soft Focus, Toy Camera, Fish-Eye and Miniature let users pick and choose how to best express their creative vision before or after the image is captured.

Enhanced EOS Full HD Movie Mode

The EOS Rebel T5i offers easy-to-use professional video capture. When users switch to EOS Full HD Movie mode, the EOS Rebel T5i offers the ability to shoot in 1080p Full HD video in a number of recording sizes and frame rates. With Canon's Hybrid CMOS AF System and Movie Servo AF, the camera provides continuous AF for focus tracking of moving subjects by helping to reduce the camera's need to "hunt", resulting in a quick and smooth continuous AF. While shooting with one of Canon's Stepping Motor (STM) lenses, such as the new EF-S 18-55mm f/3.5-5.6 IS STM lens, the camera will only capture the stereo sound of the scene being recorded. For added flexibility, the EOS Rebel T5i also features a built-in stereo microphone with manual audio level adjustment to enhance sound quality.

Canon is expanding the lineup of STM lenses by adding one new lens, which now gives users three choices that will allow for the capture of stunning images and video with the EOS Rebel T5i ↔ ↔ the EF-S 18-135mm f/3.5-5.6 IS STM, the EF 40mm f/2.8 STM and the new EF-S 18-55mm f/3.5- 5.6 IS STM lens. The EF-S 18-55mm f/3.5-5.6 IS STM lens offers high magnification in a compact and lightweight EF-S standard zoom lens with an optical image stabilizer for up to four equivalent stops for shake correction. When paired with the Hybrid CMOS AF, it allows for smooth and quiet, continuous AF for photo and video capturing - making it the perfect combination for preserving those once in a lifetime moments. ↔

Availability

The EOS Rebel T5i Digital SLR camera is scheduled to be available in April for an estimated retail price of \$749.99 for the body alone; \$899.99 bundled with an EF-S 18-55mm f/3.5-5.6 IS STM lens kit, and \$1,099.00 with the EF-S 18-135mm f/3.5-5.6 IS STM lens kit. About Canon U.S.A., Inc. Canon U.S.A., Inc., is a leading provider of consumer, business-to-business, and industrial digital imaging solutions. With approximately \$40 billion in global revenue, its parent company, Canon Inc. (NYSE:CAJ), ranks third overall in U.S. patents registered in 2012? and is one of Fortune Magazine's The new EF-S 18-55mm f/3.5-5.6 IS STM lens also is also scheduled to be available separately in April at an estimated retail price of \$249.99. For more information about the Canon EOS Rebel T5i Digital SLR Camera, the full list of product specifications and compatible lenses, visit www.usa.canon.com/eos.